

MAVERICK™ **Simpler. Faster. Smarter.**



Efficient pre-assembly cuts onsite labour



Arrives on site mechanically and electrically prefabricated

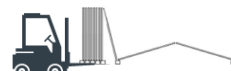

Rapidly deployed on site

Mechanical Specifications

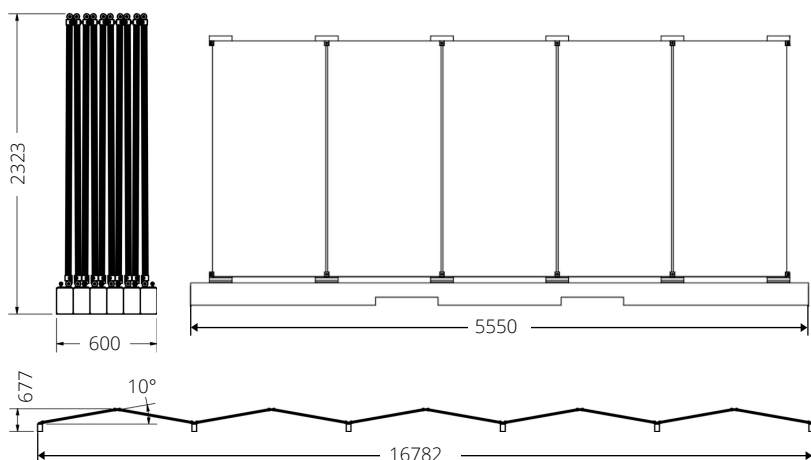

MAV model	5BAU-MAV-5P5B-16S-JAM72S10 390-410/PR
Module Configuration	40 modules per MAV, 5 wide x 8 long
Module Dimensions	40 (H) x 996 (W) x 2015 (L) mm
Packed Dimensions	5550 (W) x 2323 (H) x 600 (L) mm
Packing Configuration	2 MAV units per 20' HQ container
Deployed Dimensions	5550 (W) x 677 (H) x 16782 (L) mm
Deployment Type	Telehandler or forklift
Tilt Angle	10 degrees, excluding ground variation
Weight	2700 kg per MAV
Module connections	Anodised aluminium alloy hinges, module clamps
Tethers	Stainless steel cable
Ballast	Precast 50MPa reinforced concrete beam
Peak wind velocity	Wind region A to B, with minor additional ballast
Beam-beam tolerance EW	Maximum 500mm

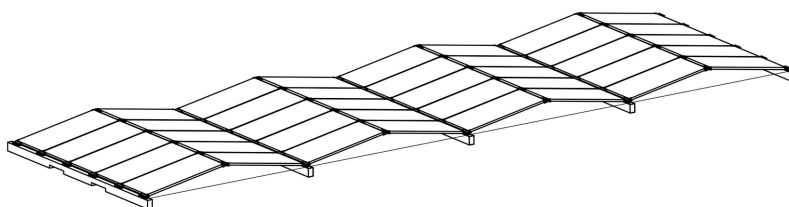

Electrical Specifications

Module

PV Module Type	JAM72S10-400/PR
Maximum Power (Pmax)	400 W
Open-circuit Voltage (Voc)	49.5 V
Maximum Power Voltage (Vmp)	41.2 V
Short-circuit Current (Isc)	10.3 A
Maximum Power Current (Imp)	9.72 A
Module Efficiency (STC)	19.9 %
Operating Temperature	-40 ~ +85 °C
Maximum Module Voltage	1000 V

Array

Power at MPP	16 kW per MAV unit
Open circuit voltage	792 V per string
Voltage at MPP	659 V per string
Short circuit current	10.3 A per string
Current at MPP	9.72 A per string
String Cabling Method	Intra-MAV
String Configuration	2 x 16S & 2 x 4s : 2 East, 2 West
Terminations	QC4
String Fuse	N/A

Certifications

Australian Patent #2015327772, Intl. Patents Pending.

The Maverick product is compliant with relevant sections of the following standards and able to be integrated into solar PV systems that are compliant with the following standards: CEC Solar installation guidelines, AS/NZS 5033, AS 1170.0, AS 1170.1, AS 1170.2, AS 1664.1, AS 3600, AS/NZS 3000, AS/NZS 4777:2005, AS/NZS 1768:2007, AS/NZS 4509:2009.

Structurally certified for transport and operation in wind regions A and B to the aforementioned standards.



ABOUT 5B

5B is an Australian engineering team dedicated to developing cutting-edge technologies that reduce the cost of renewable energy. 5B's Maverick is the only re-deployable solar array that is cheaper and faster to install than conventional solar.

